

ZONE		REV	DESCRIPTION	DATE	APPROVED
A			Final 3' iter - was 3' iter 2'	4/26/99	D.P.

### KNEE HINGE DETAIL

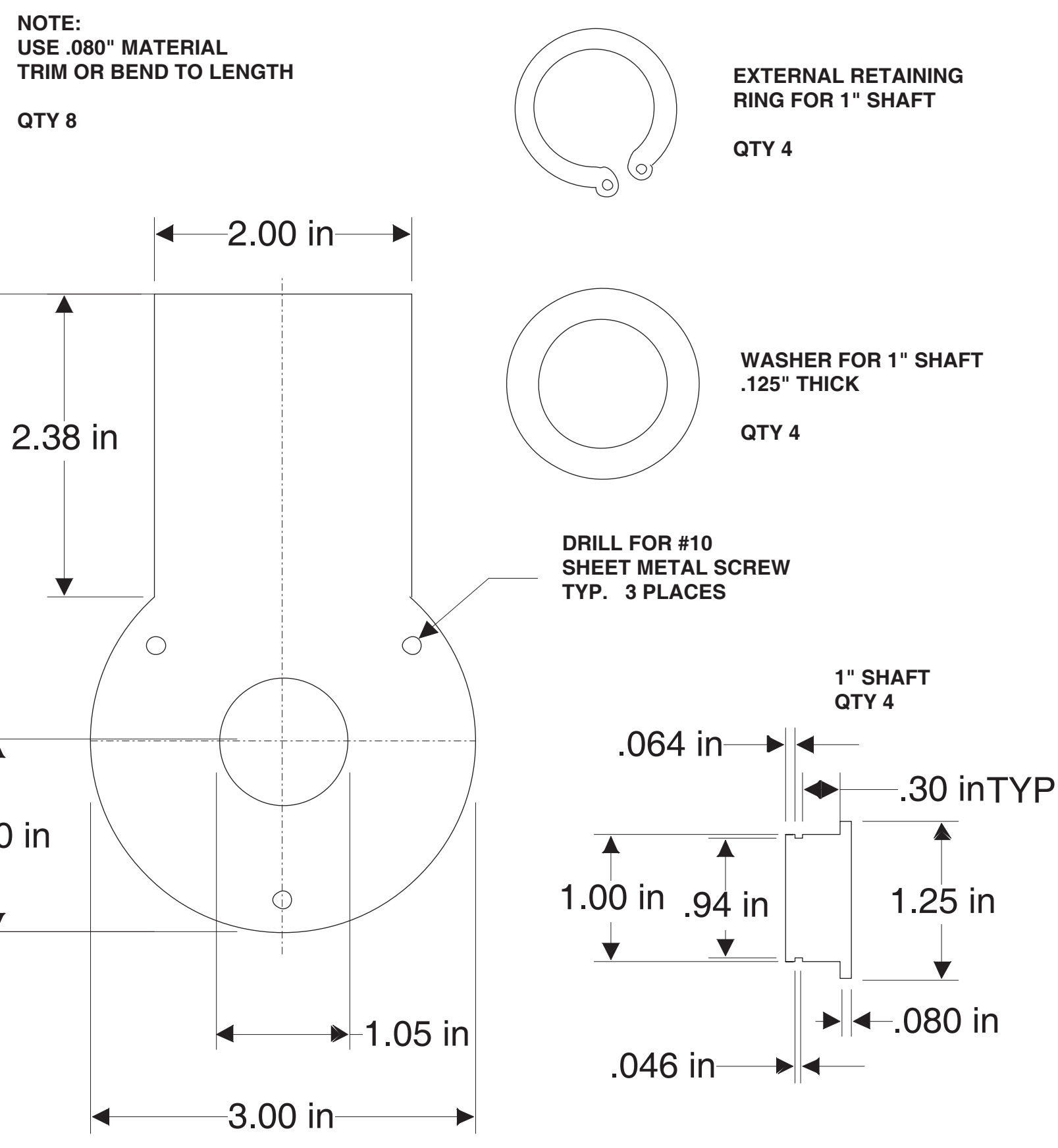

### WHEEL DETAIL

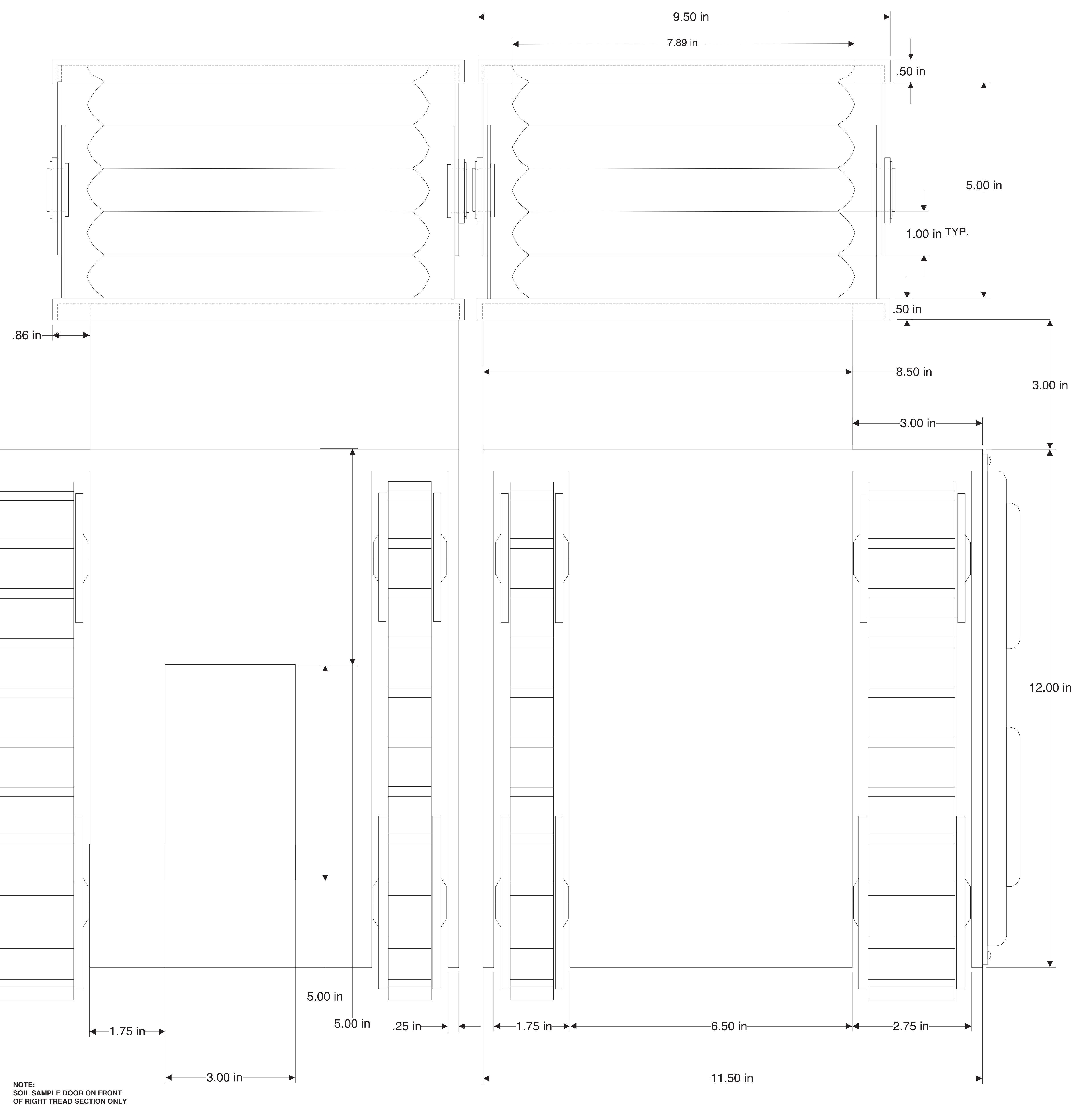
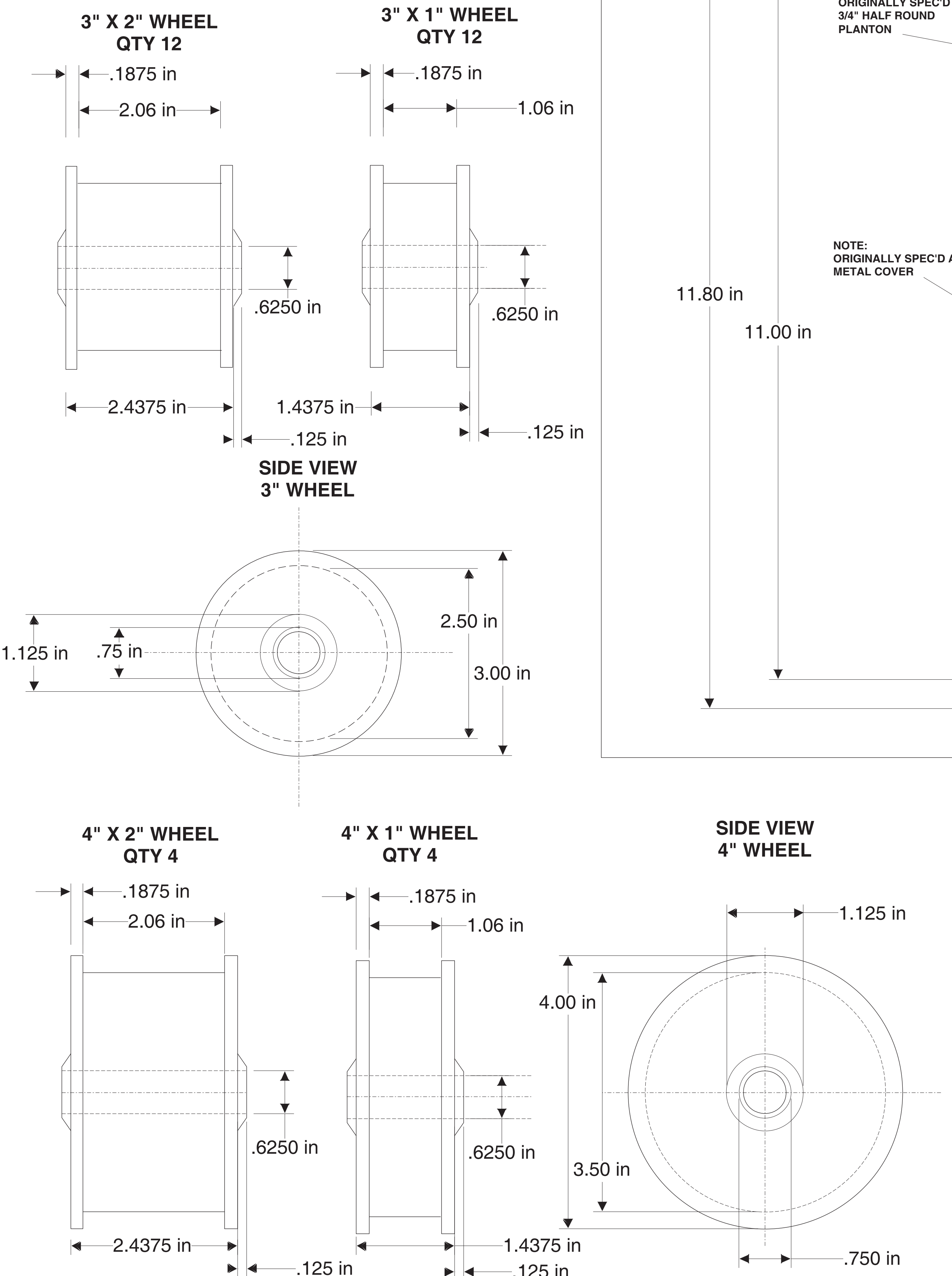

### FRONT VIEW

<b>ROBOT B9</b>			
<b>KNEE &amp; TREAD</b>			
D. Painter	SIZE: 3/5/99	DWG. NO.	REV: A
<i>D. Painter</i>	SCALE: 1:1	SHEET: 1 of 2	